

# Industrial Lobe Pumps

## RL Series

Section	270
Page	270.1
Issue	A

### Performance

Size	Nominal Capacity		Pressure			
			Standard 2-Bushing Design		High Pressure 4-Bushing Design	
	GPM	M <sup>3</sup> /hr	PSI	BAR	PSI	BAR
RL016	105	23.8	250*	17	400*	27
RL025	160	36.3	175	12	400*	27
RL150	820	186	N/A	N/A	400	27

\* Packed Pumps are limited to 200 PSI (14 bar)

Temperature Range		Viscosity Range**	
°F	°C	SSU	cSt
-40 to 400*	-40 to 205*	31 to 2,000,000	1 to 440,000

\* Special sealing or materials may be required.

\*\* Optional low viscosity construction (reduced clearances) may be required below 750 SSU

### Product Description

The RL Series timed rotary lobe pumps with bi-wing lobes have been designed exclusively for industrial applications. They combine these four key benefits:

- Maintain product integrity, especially for shear-sensitive fluids, suspensions or dispersions.
- Provide a variety of sealing options, allowing end users to purchase seals from their vendor of choice.
- Provide higher pressure capabilities than traditional rotary lobe pumps.
- Provide ease of maintenance, including cleaning and lobe clearance adjustment. Simple timing design requires no shimming.

The RL Series efficiently handles a broad range of fluids, from water-like to highly viscous, while minimizing fluid shear and pulsation. The unique, patented design emphasizes flexibility in sealing, porting and lobe clearance adjustment to optimize the pump for each application. Lobe timing has been simplified for ease of operation and maintenance. An extremely robust design has been employed to prevent shaft deflection and ensure an exceptionally long service life, even on difficult applications.

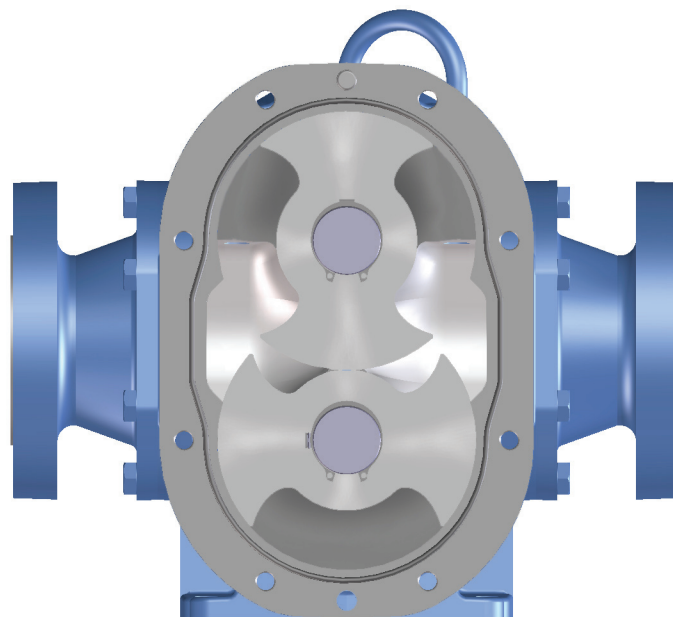

RL40167 with front cover removed

### Nomenclature

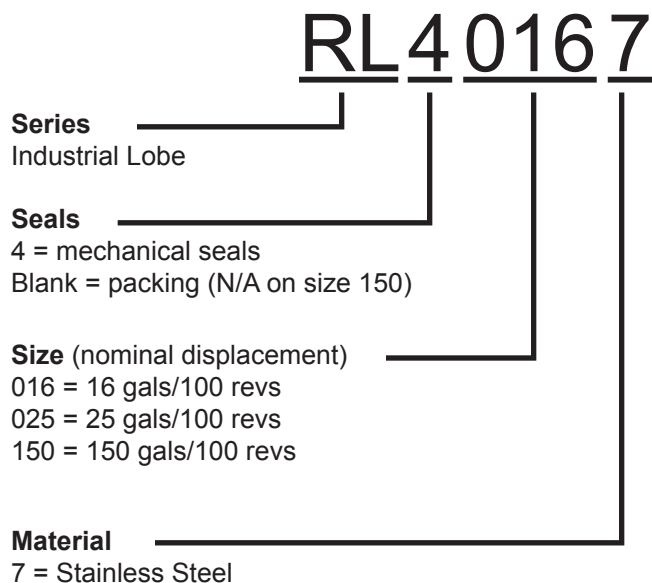

The RL Series come standard with 2 bushings behind the lobes. The high pressure design has bushing support on both sides of the lobes. This is standard on size 150, and optional on the smaller sizes. The model number does not differentiate between the standard or high pressure designs. To get a high pressure pump on the smaller sizes, use the standard model number (e.g. RL40257) and order the high pressure option.

Section	270
Page	270.2
Issue	A

# Industrial Lobe Pumps RL Series

## Major Design Features

Shaft sealing options include cartridge-style single and double mechanical seals and cartridge-style triple lip seals on all sizes. Packing and component-style single mechanical seals are also available on the RL016 and 025 pumps. These pumps were designed to offer maximum flexibility, using standard size, off-the-shelf seals from major manufacturers. Features include:

- Double tapered roller bearings in a patented threaded, adjustable housing, which allows lobe clearance adjustments without shiming and without complete pump disassembly.
- Porting flexibility, to match the correct port size to the customer's piping, is provided through an enlarged suction area with bolt-on ports on the RL016 and 025, (3" & 4") and three port size options (6", 8" & 10") on the RL150.
- Bi-wing lobes offer maximum surface sealing area for high efficiency. The large voids gently handle fluids that are shear-sensitive or have entrained solids.
- Enlarged loading cavities on three sides of the lobes minimize fluid pulsation and improve suction characteristics on highly viscous fluids.
- Optional low viscosity construction with reduced clearances is available on the RL016 and RL025 for thin liquid applications. This minimizes slip to provide highest volumetric efficiency and maximum discharge pressure, even on water-like fluids.
- Reversible direction of flow. The pump can be run in either direction. Some modifications may be required. Consult the factory for details.
- The extra-large helical timing gears reduce noise, provide high load-carrying capabilities, and offer long life. Timing gear adjustment is simply done by matching two marks on each gear, and locking tang washers in place.
- Temporary run-dry capability. Because the timed lobes are non-contacting, the pump may be run dry for short periods, if a seal flush/quench and lubricating fluid film on the bushings are present.



RL40167 Industrial Lobe Pump

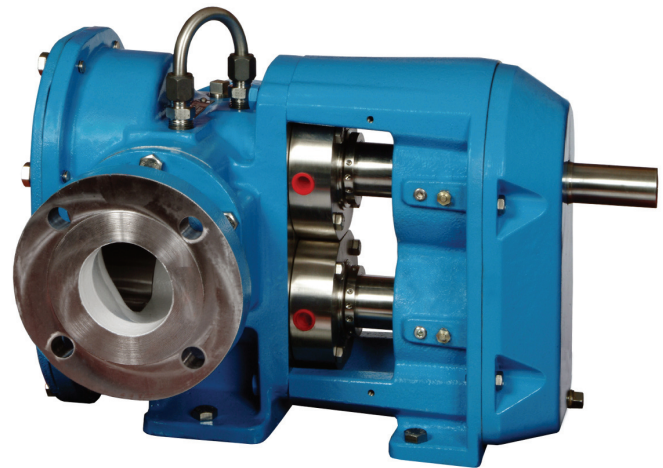

RL40167 (shaft guards removed)

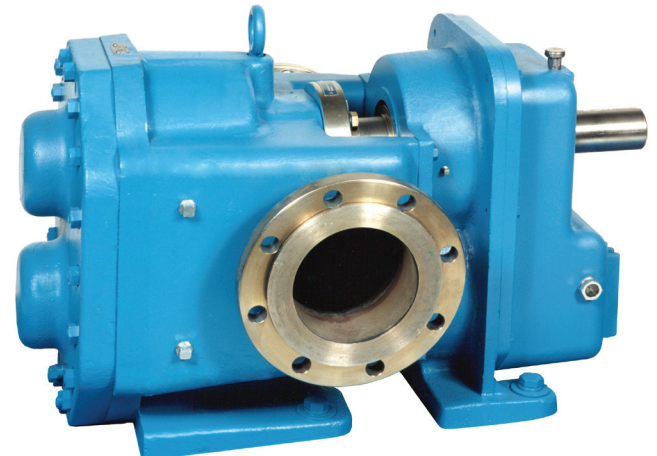

RL41507 (shaft guard removed)

# Industrial Lobe Pumps RL Series

Section	270
Page	270.3
Issue	B

## Feature Overview

### Extended Seal Life

- Enlarged suckback tube vents air from both seal chambers to prevent dry seal faces. Shaft support on both sides of seal prevents deflection and seal wear.

### Ease of Reassembly

- Dowel pins ensure true alignment upon reassembly, to prevent lobe contact and extend seal life.

### Sealing Flexibility

- Accepts cartridge mechanical seals from most manufacturers (or packing or component mechanical seals on the RL016 and 025).

### Simple Lobe Clearance Adjustment

- Just rotate the adjustable bearing housing and lock with a set screw. No shimming!

### Enlarged Loading Cavities

- Three-side access improves suction side filling and reduces discharge side trapping pressure pulsations.

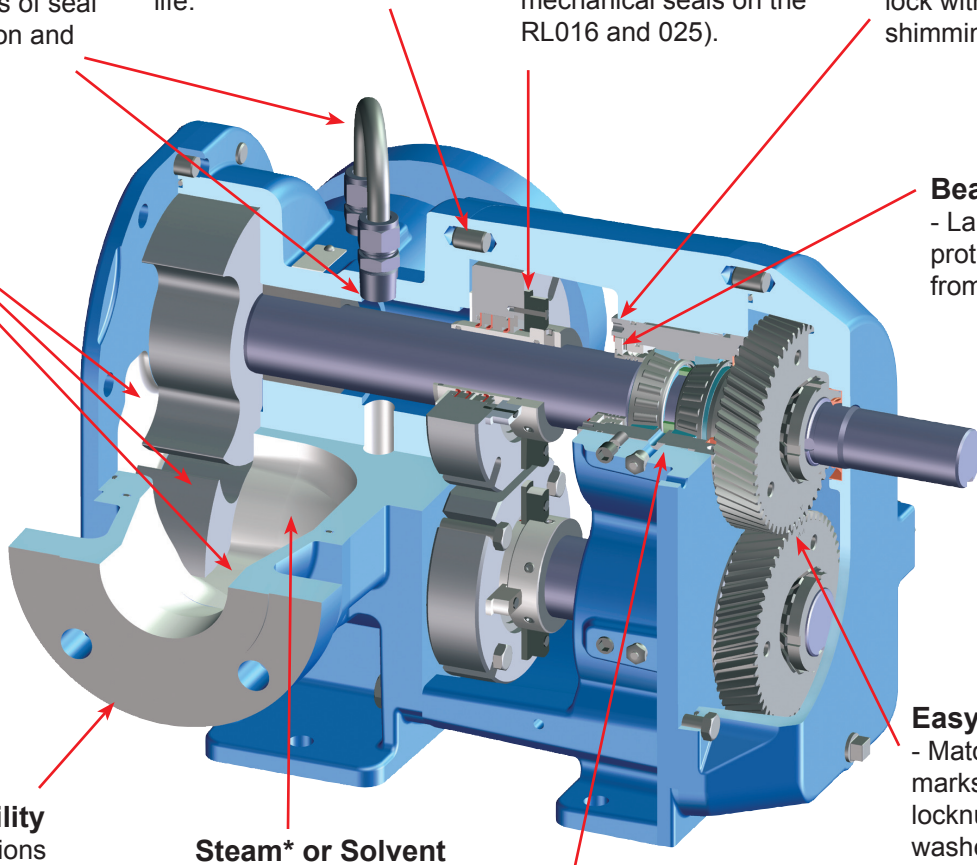

### Bearing Isolation

- Labyrinth seals protect thrust bearings from contamination.

### Easy Timing

- Match the timing gear marks and secure the locknut with the tang washer. No shimming!

### Porting Flexibility

- Bolt-on port options on smaller sizes, plus 3 port size options on the RL150, ensure correctly sized ports are available to match the application.

### Steam\* or Solvent Cleanable

- Designed for applications where frequent cleaning is required.

### Thrust Control

- Regreasable, double-row tapered roller bearings handle radial and axial thrust (RL016, RL025).

### High Pressure

- Optional high pressure design (standard on RL150) uses pumpage-lubricated bushings on both sides of the lobes to prevent shaft deflection and allow pressures to 400 psi (27 bar).

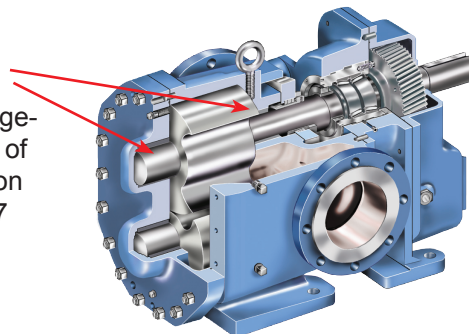

### Lobe Retention

- Lobes on standard RL016 and RL025 pumps are secured by means of snap rings, allowing replacement of lobes. Lobes on high pressure models, including RL150s, are press fit onto shafts.

\*Steam temperature is limited to 275 °F (135 C)



Section	270
Page	270.4
Issue	B

# Industrial Lobe Pumps RL Series

## Specifications

Model Nos.		Port Size*		Nominal Capacity (at max. speed, w/162 cSt fluid)		Max. Speed RPM	Max. Discharge Pressure				Max. Hydrostatic Pressure		Max. Temperature		Shipping Weight (High Pressure Design)	
Packed	Mechanical Seal	Std.	Optional				Standard 2-Bushing Design		High Pressure 4-Bushing Design							
		(in.)	(in.)	GPM	M <sup>3</sup> /hr		PSI	Bar	PSI	Bar	PSI	Bar	°F	°C	Lbs	Kg
RL0167	RL40167	3"①	3"③ 4"①③	105	23.8	640	250	17	400	27	600	40	400	204	281 (305)	128 (139)
RL0257	RL40257	3"①	3"③ 4"①③	160	36.3	640	175	12	400	27	600	40	400	204	297 (321)	135 (146)
N/A	RL41507	6"②	8"②④ 10"②④	820	186	600	N/A	N/A	400	27	600	40	400	204	1160	530

\* Raised face flanges are standard. Pumps may be ordered with one port (usually suction) larger than the other port, using any of the optional port sizes.

① Ports are suitable for use with 150# ANSI steel or stainless steel companion flanges or flanged fittings

② Ports are lap joint flanges suitable for use with 150# ANSI steel or stainless steel companion flanges or flanged fittings

③ Ports are suitable for use with 300# ANSI steel or stainless steel companion flanges or flanged fittings

④ Ports are lap joint flanges suitable for use with 300# ANSI steel or stainless steel companion flanges or flanged fittings

## Construction

Component	Standard		Options	
	RL016-025	RL150	RL016-025	RL150
Casing & Head	316 Stainless Steel			
Lobes	Stainless Steel ASTM 743 Grade CF8M Surfaced Hardened			
Shafts	Stainless Steel ASTM A564 Type 630 Surfaced Hardened			
Bushings	PEEK® (Poly Ether Ether Ketone)		Contact Factory	
O-Rings	Viton®		Kalrez®	
Bracket	Cast Iron			
Gear Case Cover	Aluminum			
Shaft Guards	Stainless Steel	Painted Steel		

PEEK® is a trademark of Victrex PLC.

Viton® and Kalrez® are registered trademarks of DuPont Dow Elastomers.

## Shaft Sealing

Size	Seal Options				
	Cartridge Single Mechanical Seal	Cartridge Double Mechanical Seal	Cartridge Triple Lip Seal	Component Single Mechanical Seal	Packed Gland
RL016	S	O	O	O	O
RL025	S	O	O	O	O
RL150	O	O	S	N/A	N/A

S = Standard; O = Optional; N/A = Not Available

RL41507 with optional  
10" ports

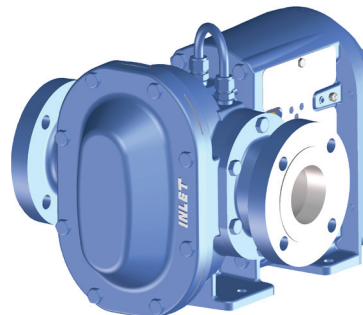
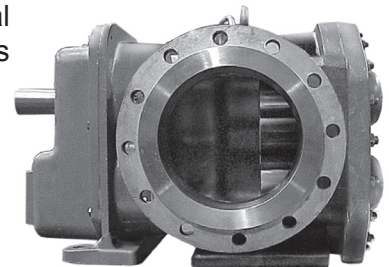

RL40257 with High  
Pressure Option

# Industrial Lobe Pumps RL Series

Section	270
Page	270.5
Issue	C

## Special Materials and Options Selection Guidelines

### High Viscosities - Above 3,300 cSt

- Sealing Considerations for viscosity (based on application requirements and experience)
  - PPC 1101V Cartridge single seal good up to 3,300 cSt.
  - Cartridge triple lip seals good up to 400,000 cSt
  - Contact factory for seal recommendations for viscosities over (3,300 cSt) when cartridge lipseal is not acceptable.
- Larger ports may be required depending on suction conditions.
- Pump may need to be operated at slower than normal speeds, which may require a larger pump.
- Additional clearances required per ES2 (Engineering Standard 2).

### For Low Viscosities Or Non-Lubricating Liquids – Below 180 cSt

- Reduced clearance lobes

### For High Temperatures – Above 212 °F to 400 °F (100° to 204 °C)

- High temperature elastomers
  - Viton® up to 350°F (177°C); or Kalrez® is rated to 500°F (260°C).
- Standard PEEK® bushings rated to 250 °F (120°C). Consult factory above 250 °F (120°C).
- Contact factory for clearance specifications.

### For Abrasive Or Dirty Liquids

- Wear resistant bushings - Contact factory.
- Hardened or hard-coated shafting.
- Abrasive-resistant seal.
- Pump should be operated at slower than normal speeds, which may require a larger pump.

Viton® and Kalrez® are registered trademarks of DuPont Dow Elastomers, LLC.  
PEEK® is a trademark of Victrex PLC.

Section	270
Page	270.6
Issue	B

# Industrial Lobe Pumps RL Series

## Mechanical Seal Options

### RL40167 & RL40257 (1.875" Shaft)

Seal Style	Seal Vendor	Seal Type	Materials Of Construction
Cartridge Single Rubber Bellows	* PPC Mech. Seals	1101V	Viton elastomers, Carbon vs Silicon Carbide seal faces, 316 S.S. metal parts and single coiled spring
		1101V	Viton elastomers, Silicon Carbide vs Silicon Carbide seal faces, 316 S.S. metal parts and single coiled spring
Cartridge Triple Lip Seal	Fluidtec	P/S-II	Viton elastomers, Gylon sealing elements, PTFE spacers, 316 S.S. metal parts
Cartridge Single Pusher	Flow-serve	ISC1PX	Viton elastomers, Carbon vs Silicon Carbide seal faces, 316 S.S. metal parts and Hastelloy C springs
	John Crane	5610	
	Flow-serve	ISC1PX	Viton elastomers, Silicon Carbide vs Silicon Carbide seal faces, 316 S.S. metal parts and Hastelloy C springs
	John Crane	5610	
Cartridge Single Metal Bellows	Flow-serve	ISC1BX	Viton elastomers, Carbon vs Silicon Carbide seal faces, 316 S.S. metal parts and Alloy 20 or Hastelloy C bellows
	John Crane	5615Q	
	Flow-serve	ISC1BX	Viton elastomers, Silicon Carbide vs Silicon Carbide seal faces, 316 S.S. metal parts and Alloy 20 or Hastelloy C bellows
	John Crane	5615Q	
Cartridge Double Pusher	Flow-serve	ISC2PP	Viton elastomers, Carbon vs Silicon Carbide seal faces, 316 S.S. metal parts and Hastelloy C springs
	John Crane	5620	
	Flow-serve	ISC2PP	Viton elastomers, Silicon Carbide vs Silicon Carbide inboard seal faces, Carbon vs Silicon Carbide outboard seal faces, 316 S.S. metal parts and Hastelloy C springs
	John Crane	5620	
Cartridge Double Metal Bellows	Flow-serve	ISC2BB	Viton elastomers, Carbon vs Silicon Carbide seal faces, 316 S.S. gland, sleeve & metal parts and Alloy 20 or Hastelloy C bellows
	John Crane	5625	
	Flow-serve	ISC2BB	Viton elastomers, Silicon Carbide vs Silicon Carbide inboard seal faces, Carbon vs Silicon Carbide outboard seal faces, 316 S.S. metal parts and Alloy 20 or Hastelloy C bellows
	John Crane	5625	

\* Standard seal on RL40167 and RL40257

### RL41507 (3" Shaft)

Seal Style	Seal Vendor	Seal Type	Materials Of Construction
Cartridge Triple Lip Seal	** Fluid-tec	P/S-II	Viton elastomers, Gylon sealing elements, PTFE spacers, 316 S.S. metal parts
Cartridge Single	Flowserve	84	Viton elastomers, Carbon vs Silicon Carbide seal faces, 316 S.S. metal parts and Hastelloy C springs
	John Crane	5610	
	Chesterton	180	
	PPC Mech. Seals	P-3F	Viton elastomers, Silicon Carbide vs Silicon Carbide seal faces, 316 S.S. metal parts and Hastelloy C springs
	Flowserve	85	
	John Crane	5610	
Cartridge Single Metal Bellows	John Crane	5615	Viton elastomers, Carbon vs Silicon Carbide seal faces, 316 S.S. metal parts and Alloy 20 or Hastelloy C bellows
			Viton elastomers, Silicon Carbide vs Silicon Carbide seal faces, 316 S.S. metal parts and Alloy 20 or Hastelloy C bellows
			Viton elastomers, Carbon vs Silicon Carbide seal faces, 316 S.S. metal parts and Alloy 20 or Hastelloy C springs
			Viton elastomers, Silicon Carbide vs Silicon Carbide inboard seal faces, Carbon vs Silicon Carbide outboard seal faces, 316 S.S. metal parts and Hastelloy C springs
Cartridge Double	John Crane	5620	Viton elastomers, Carbon vs Silicon Carbide seal faces, 316 S.S. metal parts and Hastelloy C springs
	Chesterton	280	
	John Crane	5620	Viton elastomers, Silicon Carbide vs Silicon Carbide inboard seal faces, Carbon vs Silicon Carbide outboard seal faces, 316 S.S. metal parts and Hastelloy C springs
	Chesterton	280	
Cartridge Double Metal Bellows	John Crane	5625	Viton elastomers, Carbon vs Silicon Carbide seal faces, 316 S.S. gland, sleeve & metal parts and Alloy 20 or Hastelloy C bellows
			Viton elastomers, Silicon Carbide vs Silicon Carbide inboard seal faces, Carbon vs Silicon Carbide outboard seal faces, 316 S.S. metal parts and Alloy 20 or Hastelloy C bellows

\*\* Standard seal on RL41507

# Industrial Lobe Pumps RL Series

Section	270
Page	270.7
Issue	A

## Shaft Sealing Options

These drawings of the RL016 and RL025 stuffing box illustrate the various shaft sealing options on those sizes, which come standard with cartridge-style single mechanical seals. Packed glands and component mechanical seals are not available on the RL41507, which has cartridge triple lip seals standard. Actual seal construction varies by manufacturer.

The suckback tube provided vents the seal chamber to the inlet port. This keeps the chamber at the lowest system pressure to insure proper seal function. When reversing the rotation on the pump, the seal chamber will experience an increase in pressure, which may affect seal performance. Refer to seal manufacturer's specifications or contact the factory for recommended pressure limits.

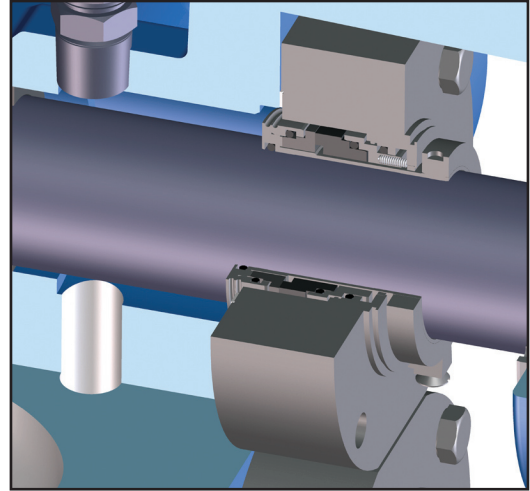

Cartridge Single Mechanical Seal

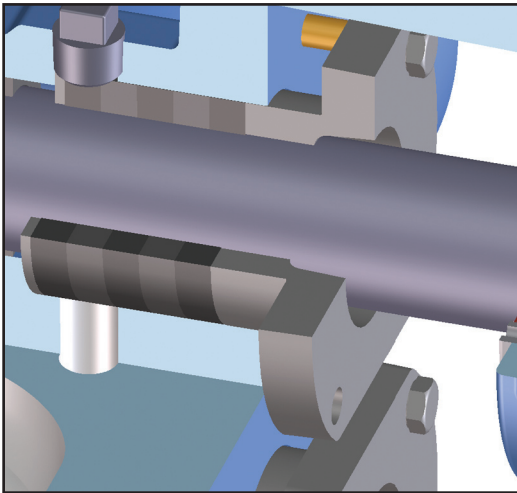

Packed Gland (limited to 200 psi/14 bar)

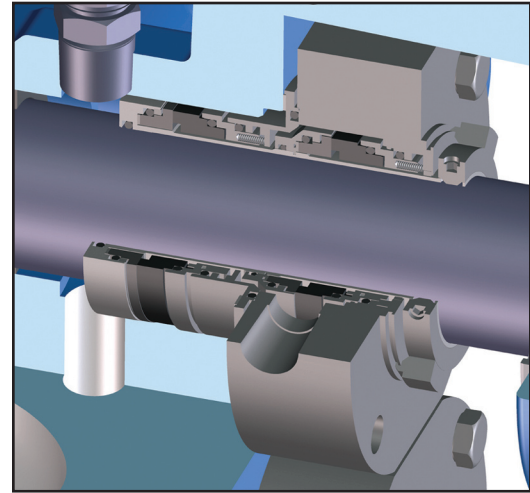

Cartridge Double Mechanical Seal

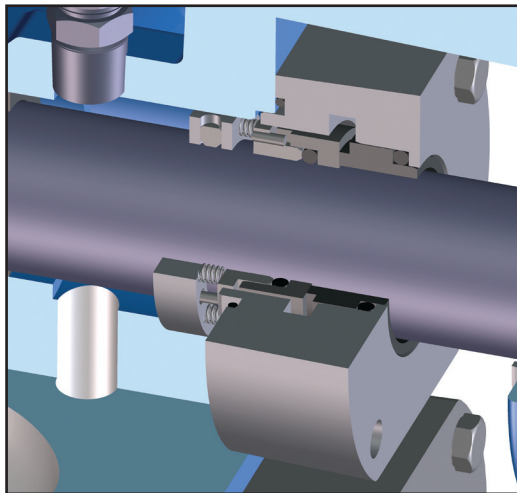

Component Single Mechanical Seal

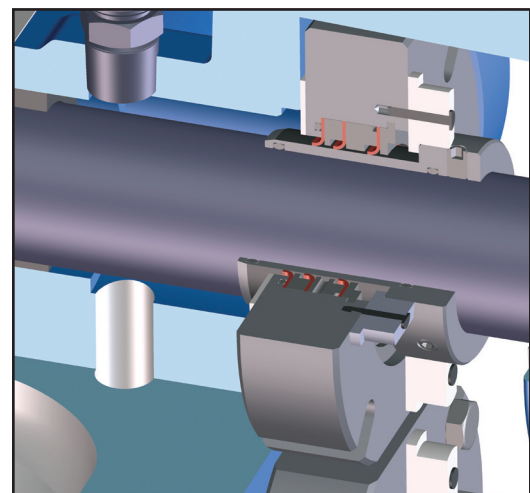

Cartridge Triple Lip Seal

Section	270
Page	270.8
Issue	A

# Industrial Lobe Pumps RL Series

## Seal Chamber Dimensions

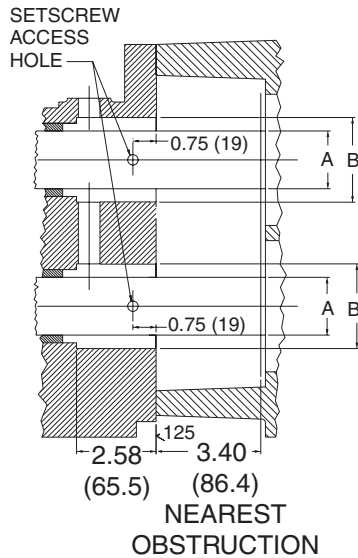

A = SHAFT DIA.  
1.875 (47.6)  
B = PACKING BORE  
2.75 DIA. (70)

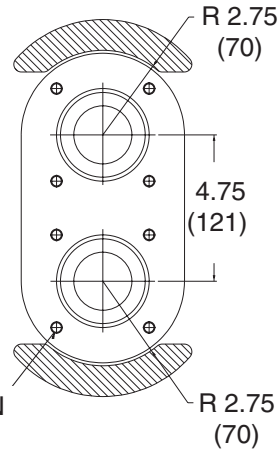

3/8-16UNC (4) HOLES  
EQUALLY SPACED ON  
A 4.250 DIA. B.C.  
(2 PLACES)

### RL016 - RL025

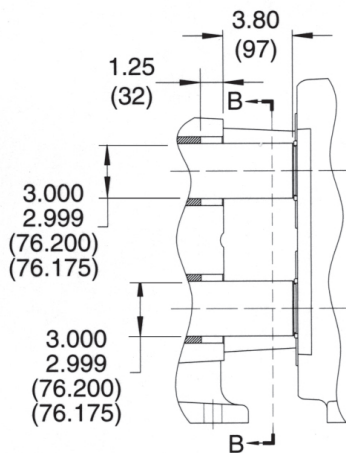

5/8-11UNC (4) HOLES  
EQUALLY SPACED ON  
A 5.75 DIA. B.C.  
(2 PLACES)

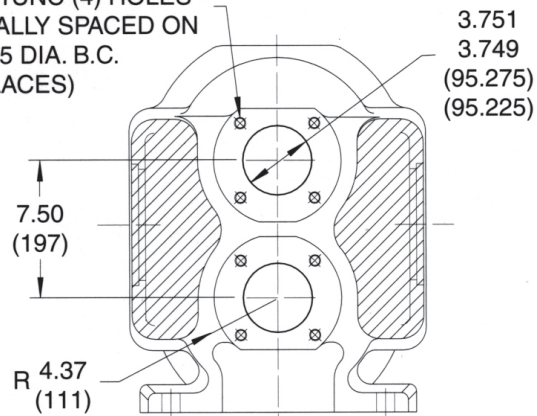

SECTION B-B

### RL150



# Industrial Lobe Pumps RL Series

Section	270
Page	270.9
Issue	B

## Dimensions

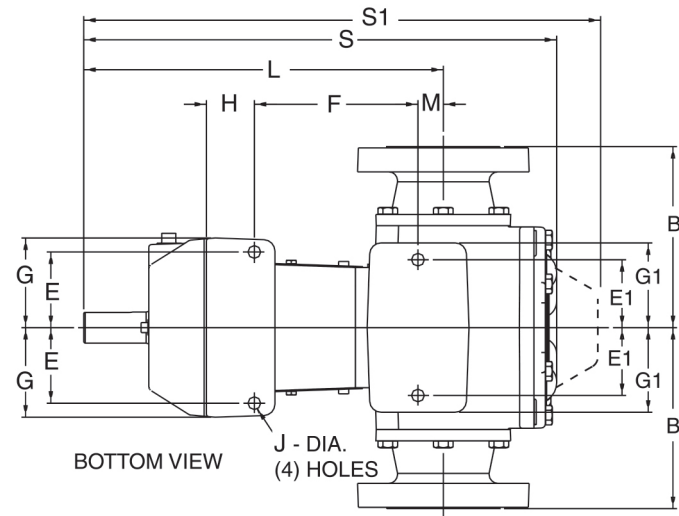
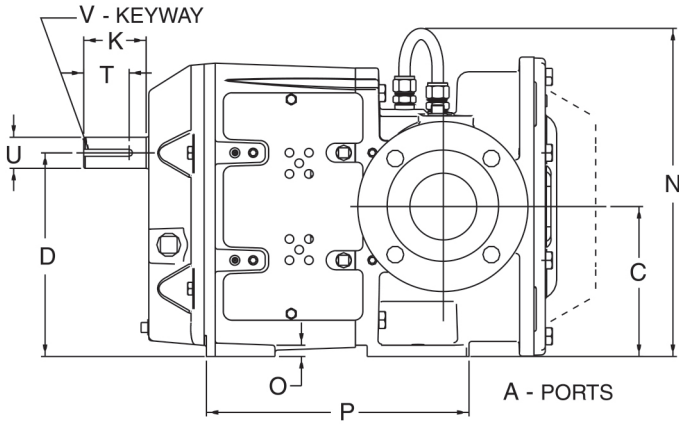

RL016 - RL025

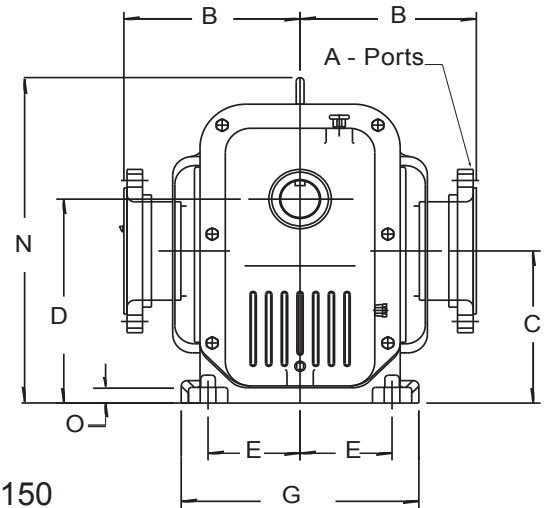
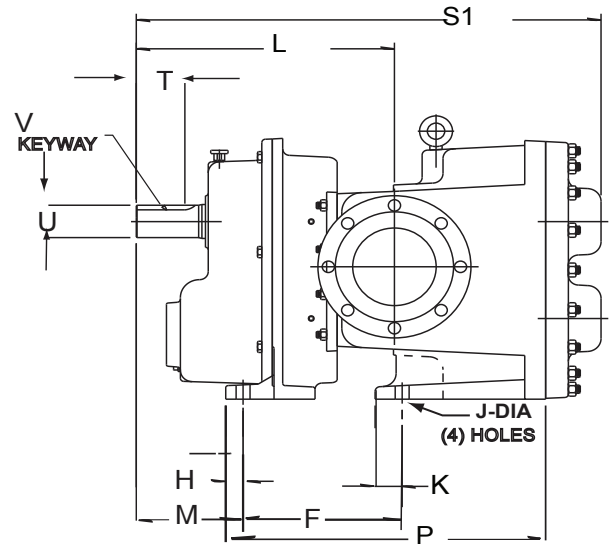

RL150

Size	Std	A①	B④⑤	C	D	E	E1	F	G	G1	H	J	K	L	M
RL016	in	3.00	8.00	6.63	9.00	3.34	3.00	7.22	3.96	3.74	2.11	0.56	2.75	15.86	1.12
	mm	76	203	168	229	85	76	183	101	95	54	14	70	403	28
RL025	in	3.00	8.00	6.63	9.00	3.34	3.00	7.22	3.96	3.74	2.11	0.56	2.75	15.86	1.12
	mm	76	203	168	229	85	76	183	101	95	54	14	70	403	28
RL150	in	6	11.25	10.25	13.75	5.88	N/A	11.34	15.17	N/A	1.35	1	1.95	18.56	7.78
	mm	152	286	260	349	149	N/A	288	385	N/A	34	25	50	471	198

Size	Std	N	O	P	S②	S1③	T	U	V
RL016	in	14.50	0.50	11.58	19.96	21.90	2.00	1.37	0.31
	mm	368	13	294	507	556	51	35	8
RL025	in	14.50	0.50	11.58	20.86	22.80	2.00	1.37	0.31
	mm	368	13	294	530	51	51	35	8
RL150	in	21.93	1.06	23.00	N/A	33.41	3.5	2.5	0.62
	mm	557	27	584	N/A	849	89	63	15.88

### NOTES

- ① Raised Face Flanges are standard on 016 and 025 Models. Lap Joint flanges are standard on 150 model. Ports are suitable for use with 150# and 300# ANSI stainless steel companion flanges or flanged fittings.
- ② Dimension for the standard pump (2-bushing).
- ③ Dimension for the high pressure pump (4-bushing).
- ④ All port options for 016 and 025 models will have the same port to port "B" dimension.
- ⑤ Optional 10" port on RL150 will have "B" dimension of 12.25 in (311.15 mm).

Section	270
Page	270.10
Issue	A

# Industrial Lobe Pumps RL Series

---

(This page intentionally left blank)

# Industrial Lobe Pumps

## RL Series

Section	270
Page	270.11
Issue	A

### Performance Curve Notes

#### INLET CONDITIONS

The performance curves show “Based on 10 In.-Hg.”, or “Based on 0 In.-Hg.” which is the standard test condition. This is not the maximum suction capability of the pump.

#### NPSH (Net Positive Suction Head)

The NPSH<sub>R</sub> (Net Positive Suction Head Required by the pump) is shown on each curve. NPSH<sub>A</sub> (Net Positive Suction Head – Available in the system) must be greater than the NPSH<sub>R</sub>. For a complete explanation of NPSH, see Application Data Sheet AD-19.

**MECHANICAL EFFICIENCY:** The Mechanical Efficiency (expressed in percent) can be calculated using the following formula:

$$\text{Mechanical Efficiency} = \frac{(\text{Differential Pressure, PSI}) (\text{Capacity, GPM}) (100)}{(\text{Horsepower, BHP}) (1715)}$$

#### FOR RL41507 NPSH<sub>R</sub> DATA CONSULT FACTORY

**METRIC CONVERSION:** The following table has been compiled for conversion to metric values.

VACUUM		PRESSURE		CAPACITY	
In.-Hg (inches of mercury)	kPa* (Kilopascals)	PSI (lb./in <sup>2</sup> )	kPa* (Kilopascals)	GPM (US gal/minute)	M <sup>3</sup> /H (Cubic Meters / Hour)
1	3.4	1	6.9	100	22.7
5	17	25	172	200	45.4
10	34	50	345	300	68.1
15	51	100	690	400	90.8
20	68	150	1034	500	113.5
25	85	200	1379	600	136
		250	1724	700	159
		400	2758	800	181

\* 100 kPa = 1 bar

Section	270
Page	270.12
Issue	A

# Industrial Lobe Pumps RL Series

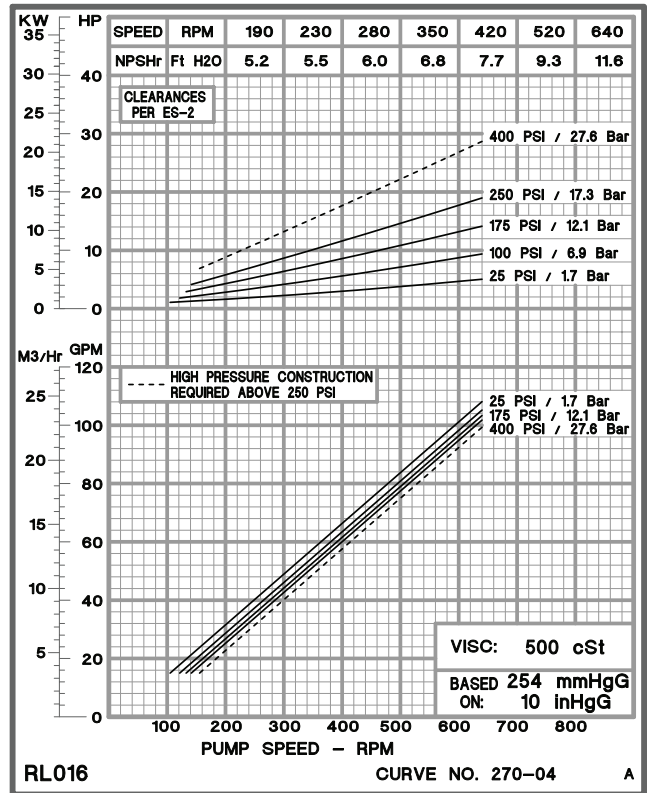
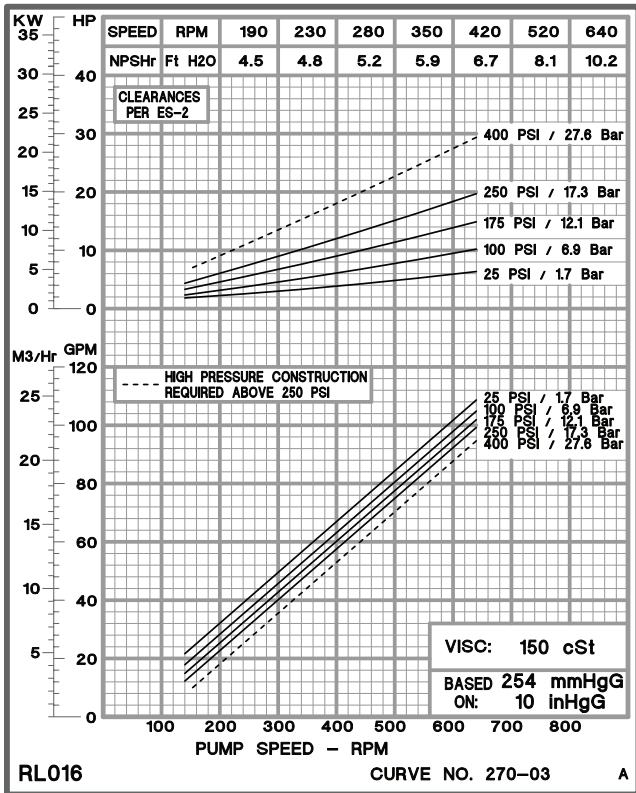
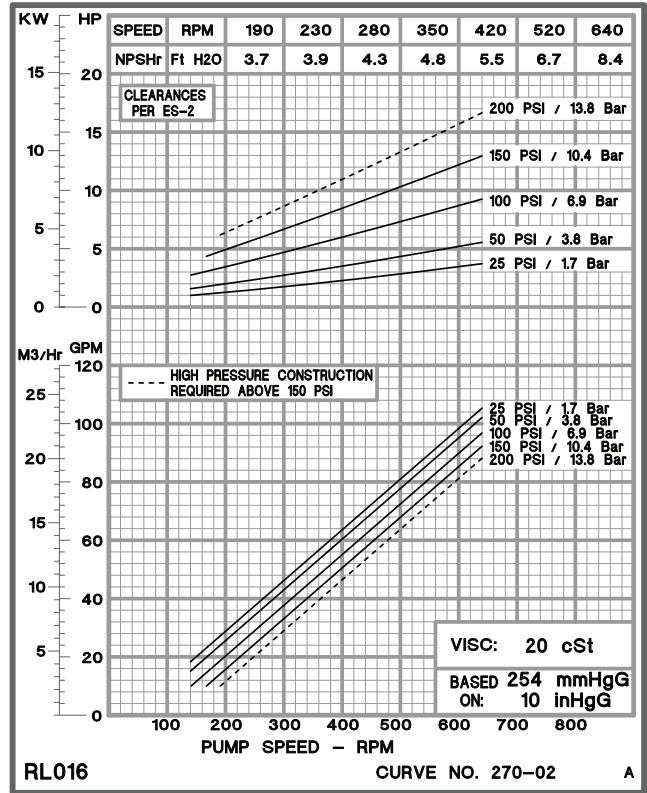
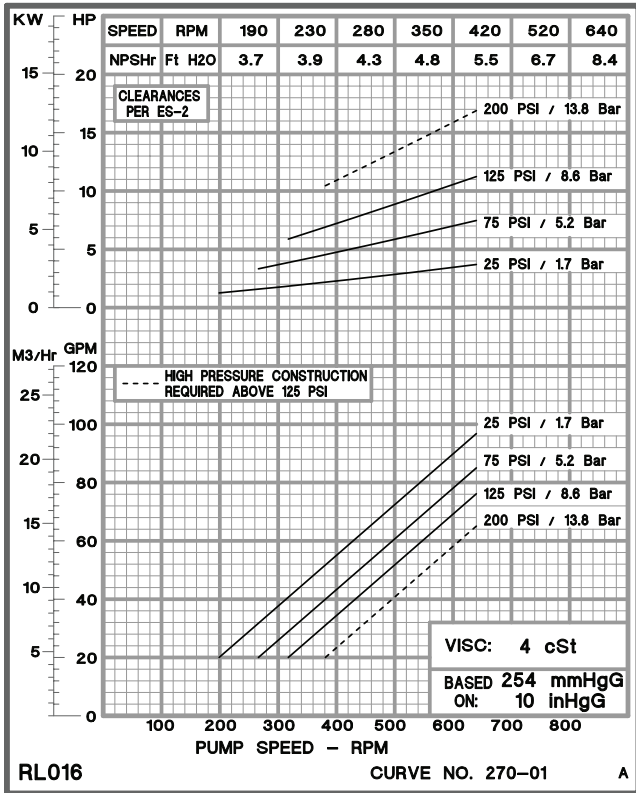



# Industrial Lobe Pumps RL Series

Section	270
Page	270.13
Issue	A

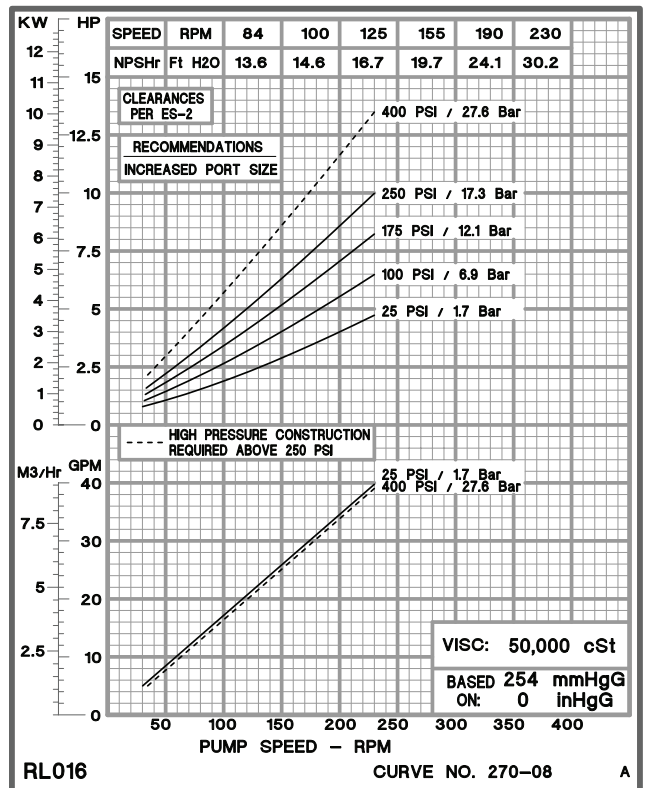
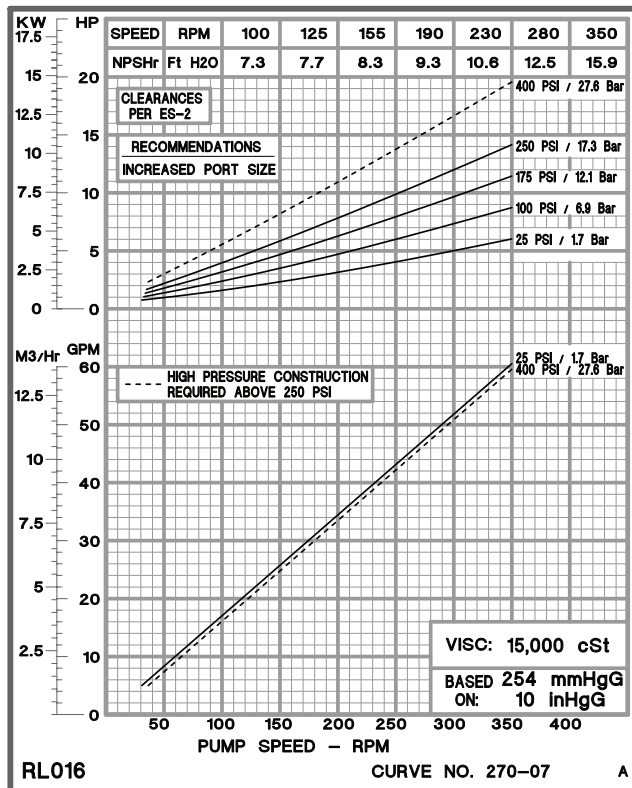
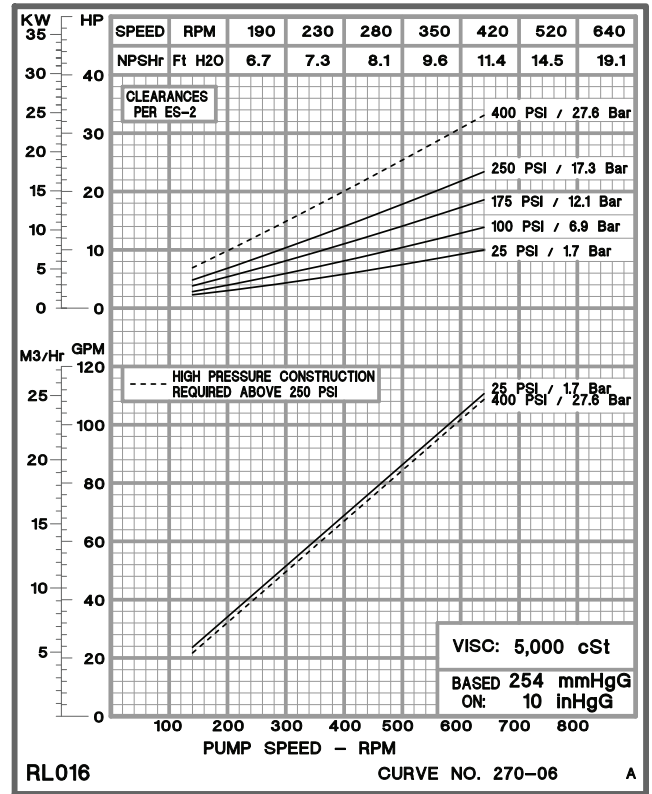
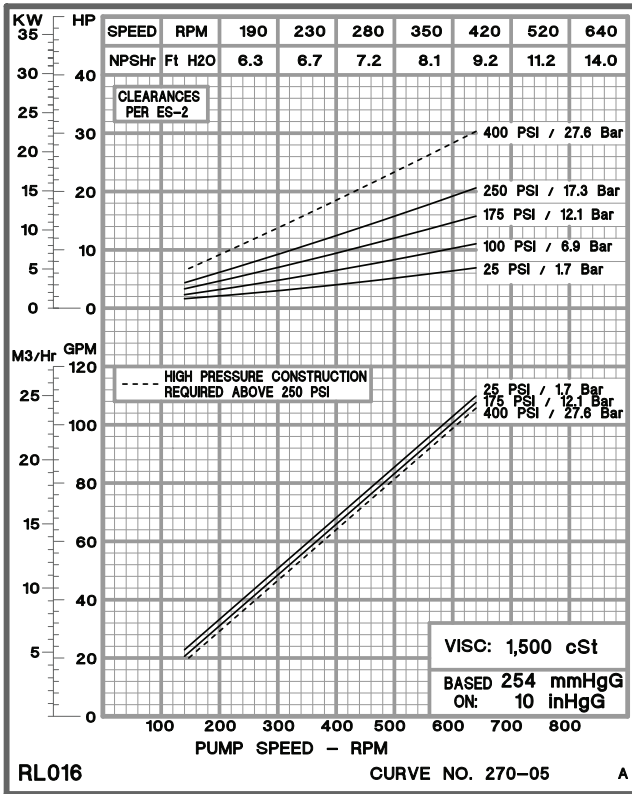

Section	270
Page	270.14
Issue	A

# Industrial Lobe Pumps RL Series

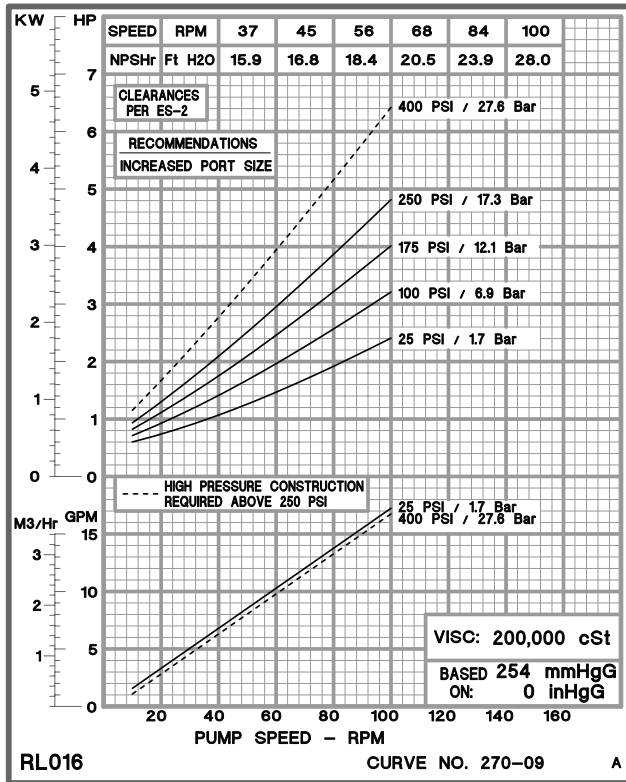

Consult Factory For Viscosities  
Above 200,000 cSt

Blank

Blank

# Industrial Lobe Pumps RL Series

Section	270
Page	270.15
Issue	A

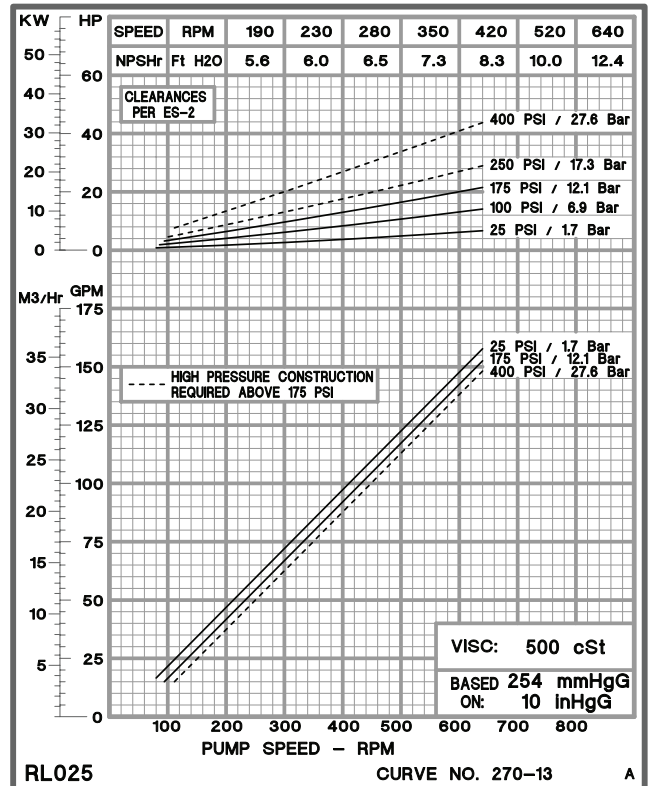
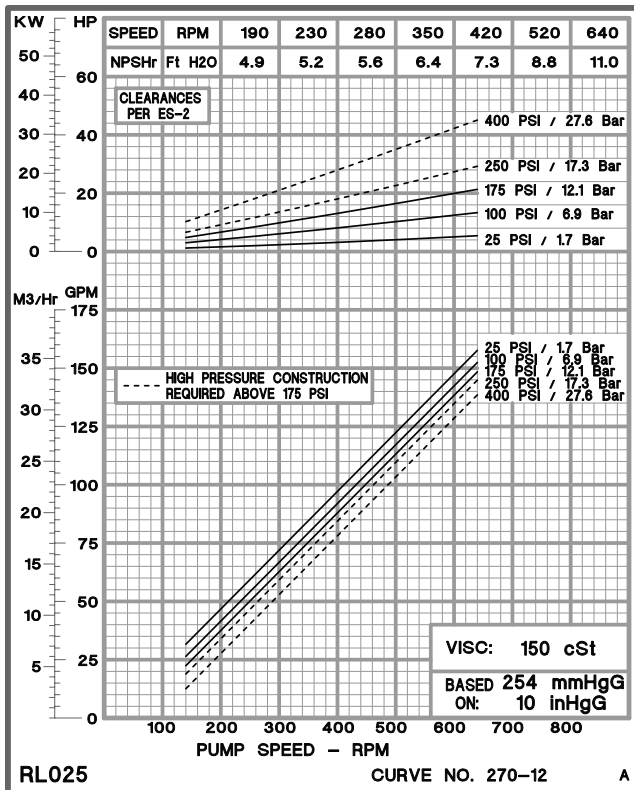
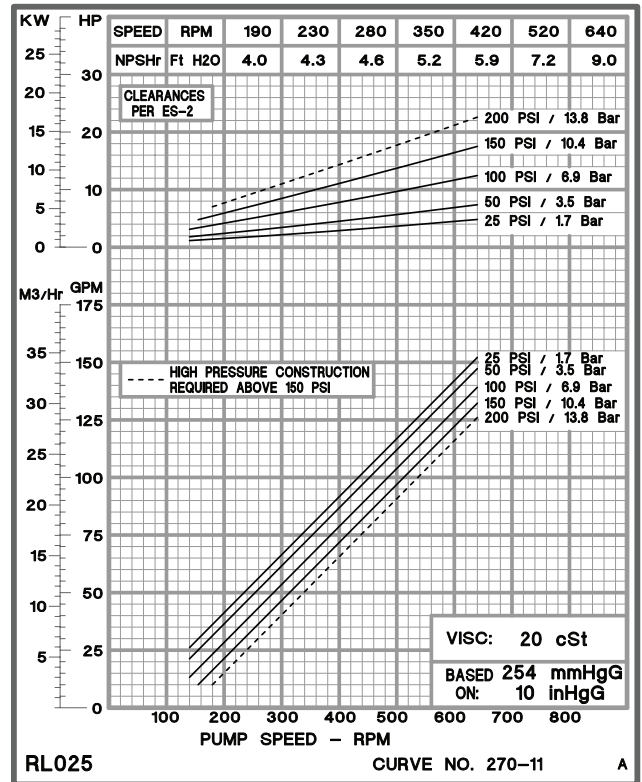
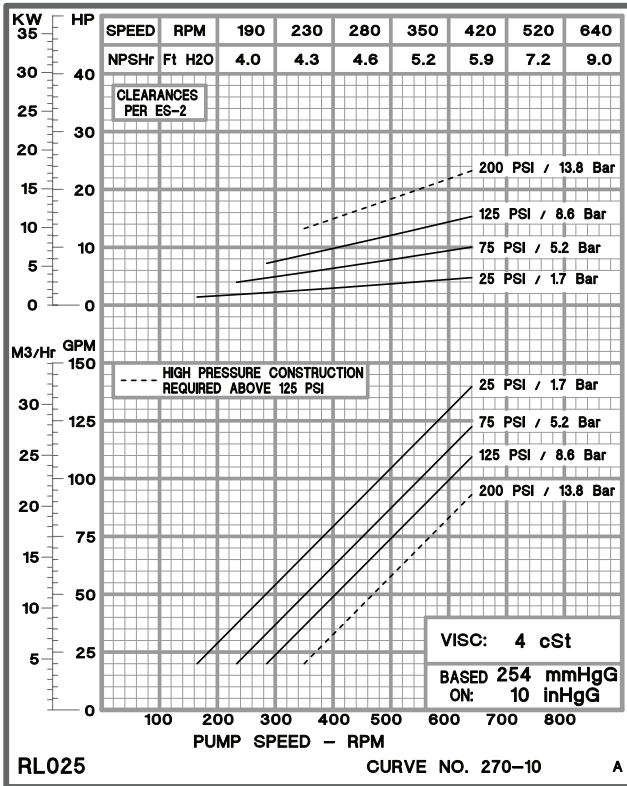

Section	270
Page	270.16
Issue	A

# Industrial Lobe Pumps RL Series

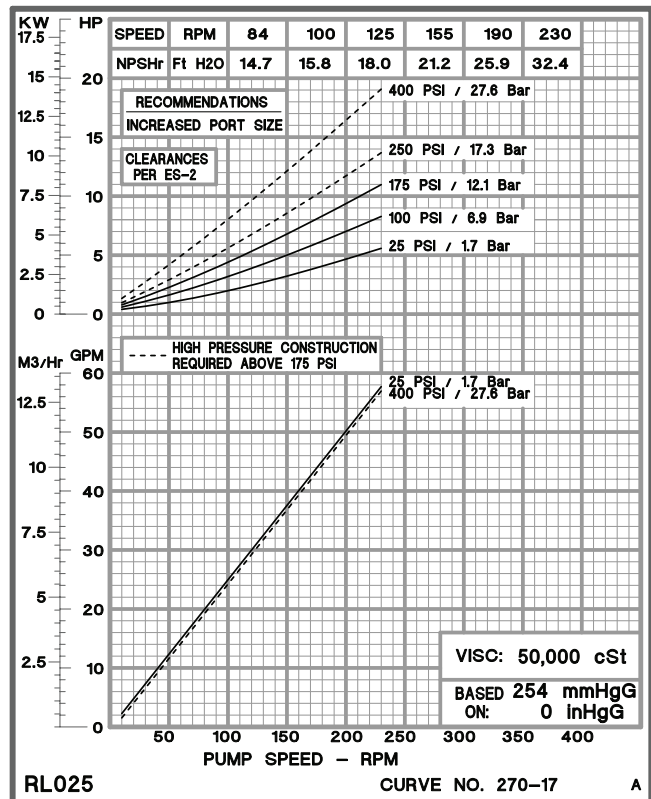
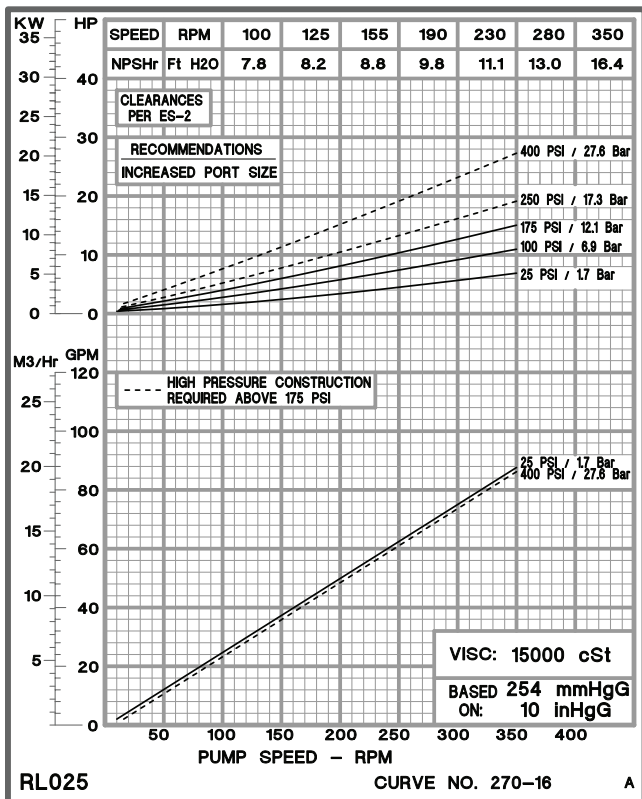
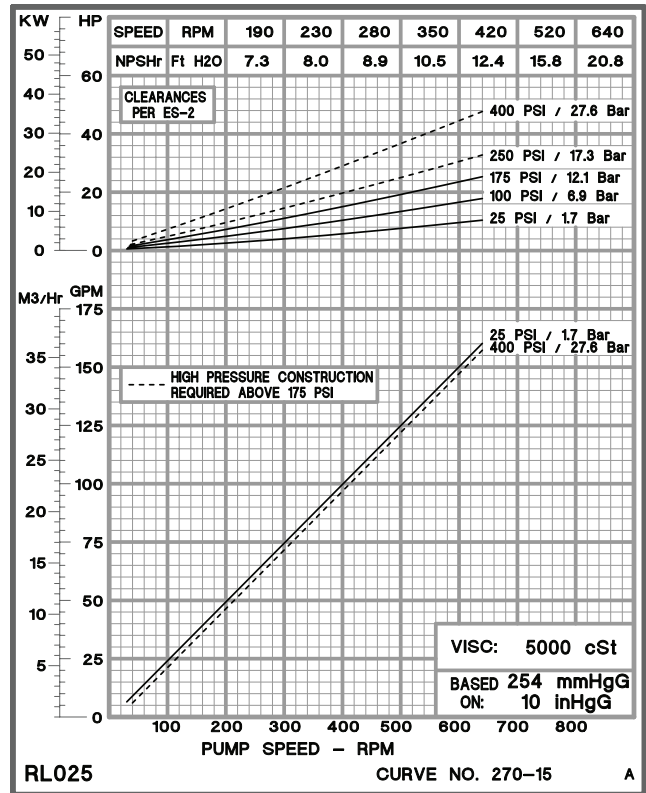
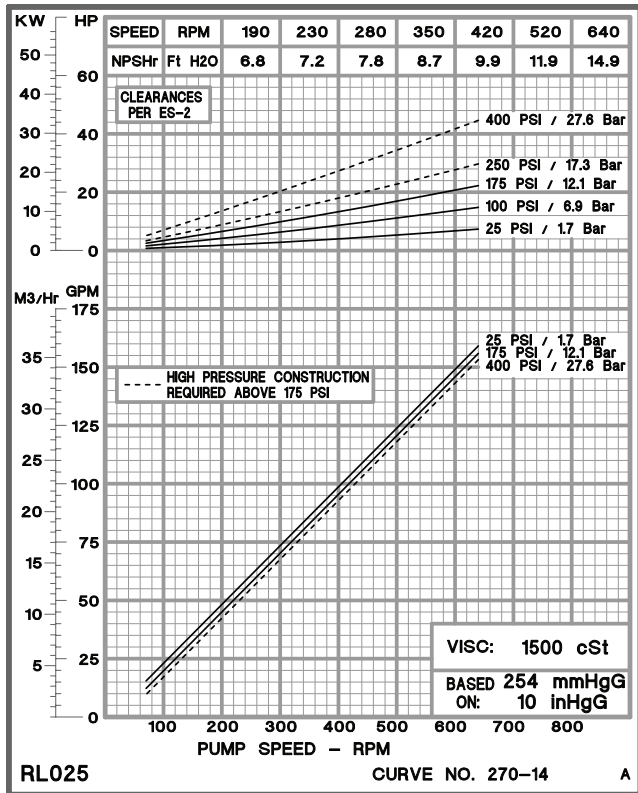



# Industrial Lobe Pumps RL Series

Section	270
Page	270.17
Issue	A

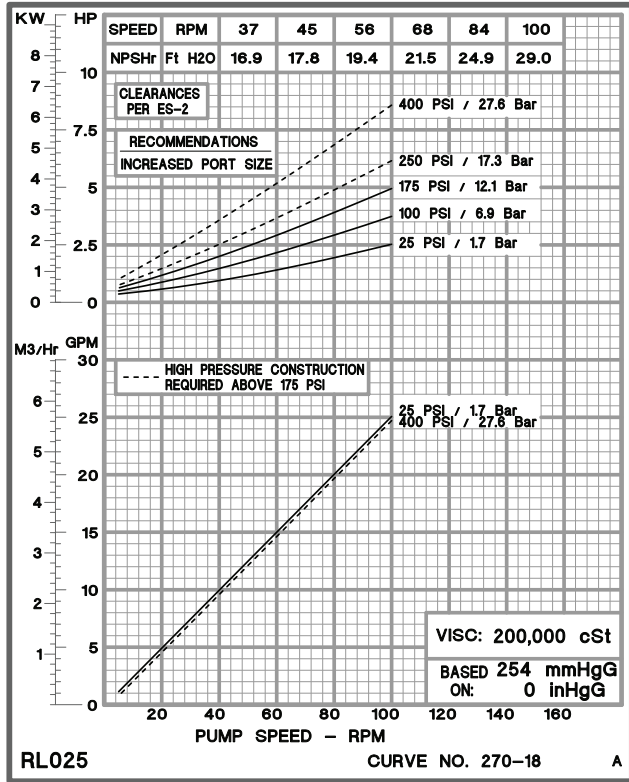

Consult Factory For Viscosities  
Above 200,000 cSt

Blank

Blank

Section	270
Page	270.18
Issue	C

# Industrial Lobe Pumps RL Series

Consult Factory For  
Viscosities Less Than  
20 cSt

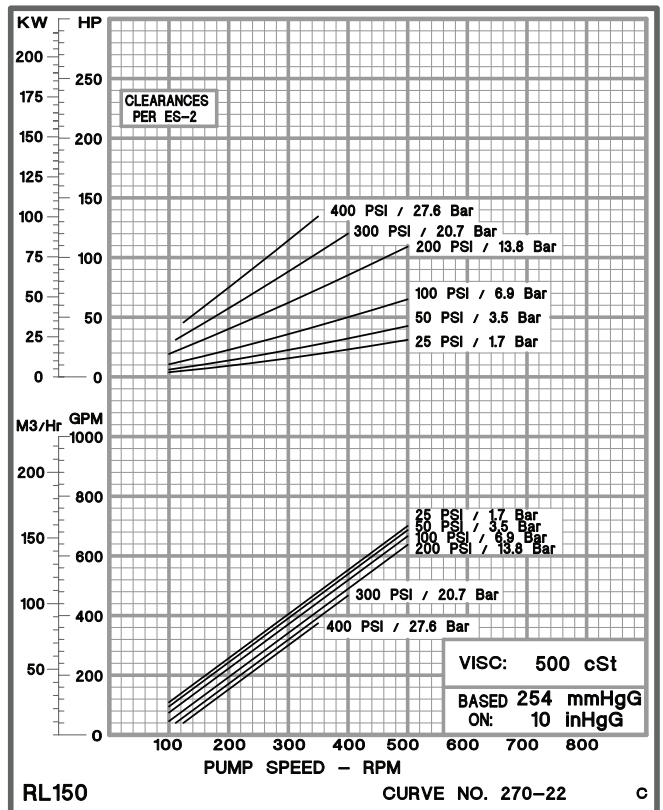
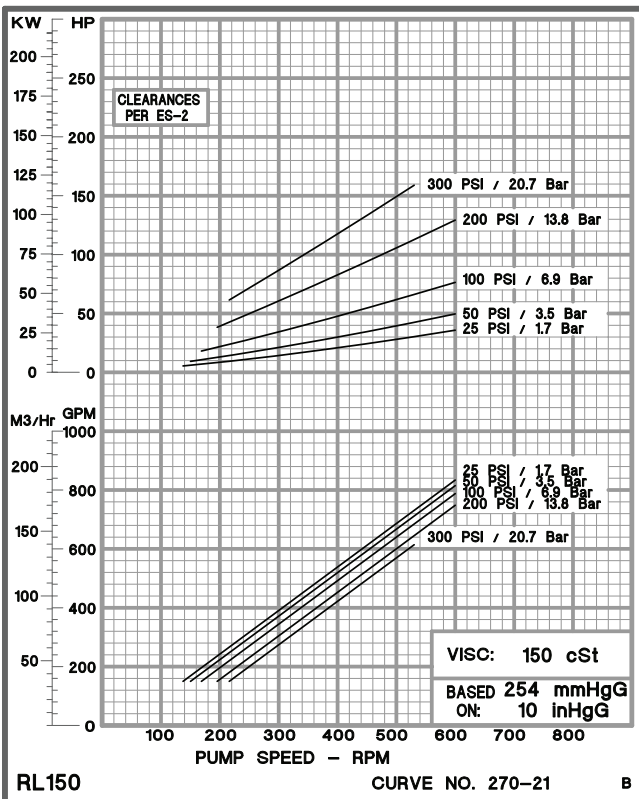
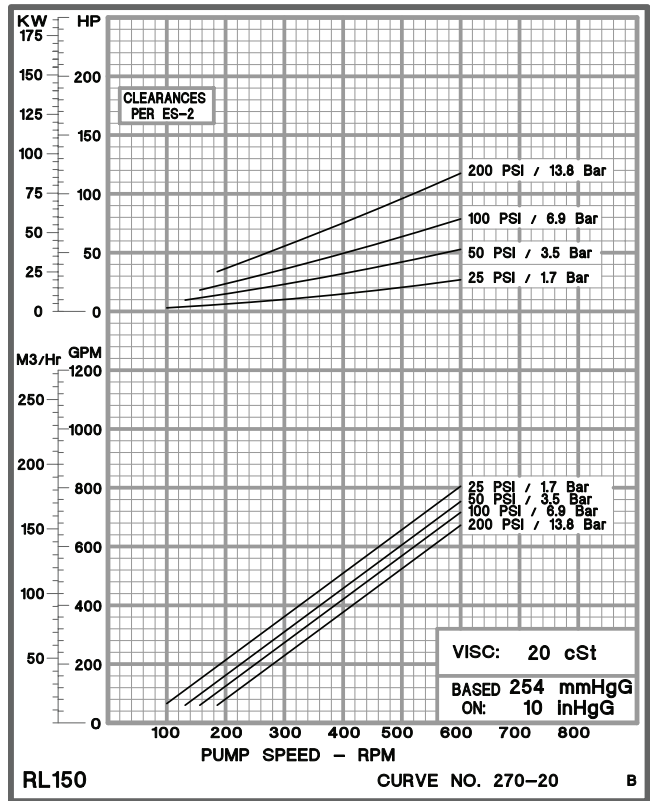

# Industrial Lobe Pumps RL Series

Section	270
Page	270.19
Issue	B

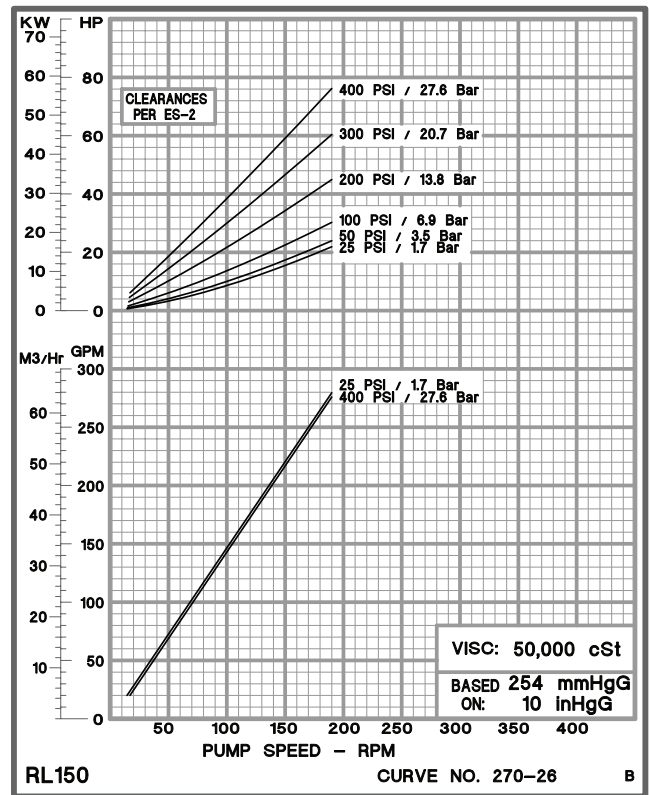
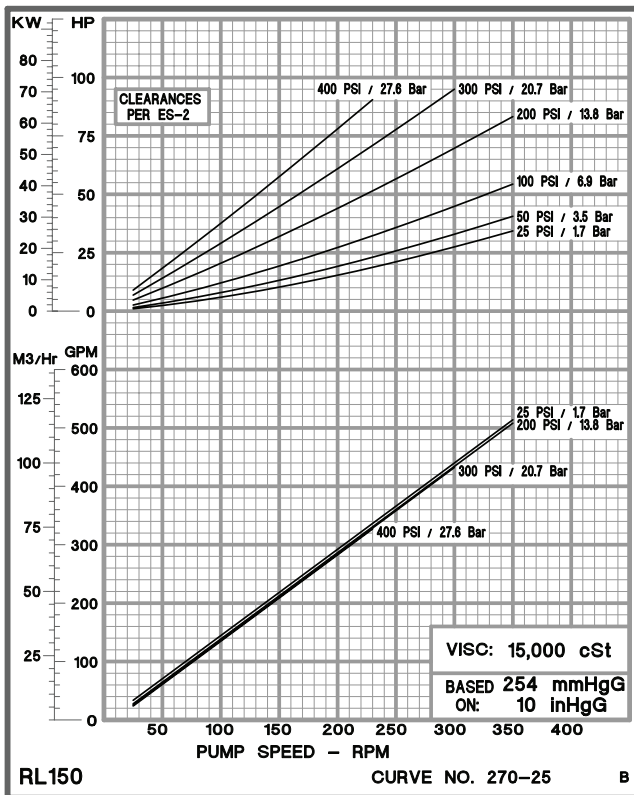
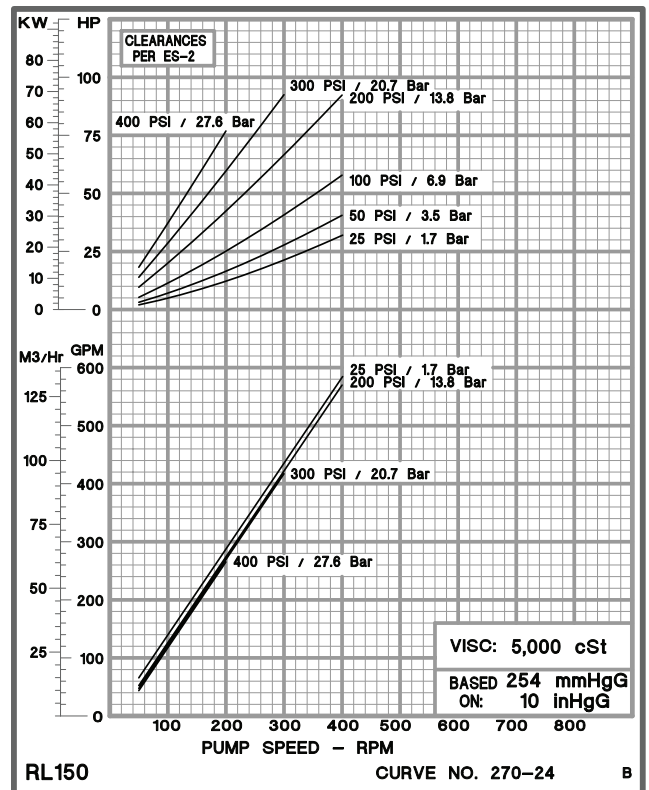
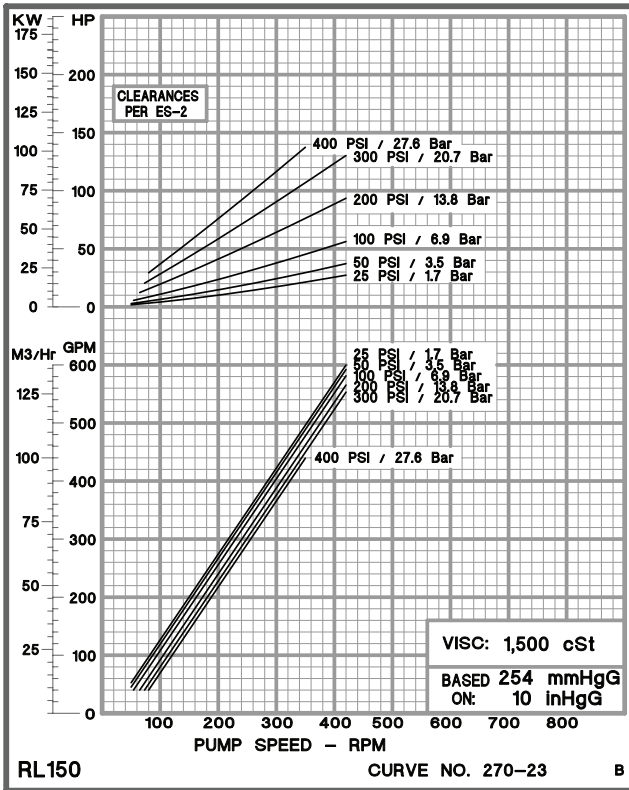

Section	270
Page	270.20
Issue	B

# Industrial Lobe Pumps RL Series

